

Primo, Duo, Trio, Quattro, Quattro Tandem



EN Montage- und Gebrauchsanweisung

The current version of the installation and operating instructions is available in the Download Center:



<http://qr.duerdental.com/5152100003>

© Dürr Dental SE

Contents



Important information

1	About this document	3
1.1	Warnings and symbols	3
1.2	Copyright information	4
2	Safety	4
2.1	Intended purpose	4
2.2	Intended use	4
2.3	Improper use	4
2.4	General safety information	5
2.5	Specialist personnel	5
2.6	Electrical safety	5
2.7	Notification requirement of serious incidents	5
2.8	Only use original parts	5
2.9	Transport	5
2.10	Disposal	6



Product description

3	Overview	7
3.1	Scope of delivery	7
3.2	Optional items	7
3.3	Wear parts and replacement parts	7
4	Technical data	8
4.1	Primo	8
4.2	Duo	9
4.3	Duo	11
4.4	Trio	12
4.5	Quattro	14
4.6	Quattro Tandem	16
4.7	Filter	17
4.8	Ambient conditions	17
4.9	Distance between rubber feet	18
4.10	Type plate	18
4.11	Evaluation of conformity	18
5	Operation	19
5.1	Duo with membrane drying unit	19



Assembly

6	Requirements	20
6.1	Installation/setup room	20
6.2	Setup	20
6.3	Information about electrical connections	20
7	Transport	21
8	Quattro Tandem assembly and installation	21
9	Installation	22
9.1	Remove the transport locks	22
9.2	Establishing the compressed air connection	22
9.3	Pressure reducer	22
9.4	Place a collector tray underneath	22
9.5	Electrical connections	22
10	Commissioning	23
10.1	Check the motor protection switch	23
10.2	Checking the switch-on/cut-off pressure	24
10.3	Draining the condensation water	24
10.4	Adjusting the rate of flow at the pressure reducer	24
11	Adjustment options	25
11.1	Adjusting the pressure switch	25
11.2	Adjusting the motor protection switch	25
12	Circuit diagrams	27
12.1	1/N/PE AC 110-127 V, 230 V layout	27
12.2	3/N/PE AC 400 V layout	27
12.3	3/N/PE AC 230 V layout, Quattro Tandem	28



Usage

13	Operation	29
13.1	Switching the unit on/off	29

- 14 Maintenance** 30
 - 14.1 Maintenance schedule 30
 - 14.2 Wear parts and replacement parts 30
 - 14.3 Changing the filter 31
 - 14.4 Checking the safety valve 32
- 15 Taking out of use** 32
 - 15.1 Taking the unit out of use 32
 - 15.2 Storage of the unit 33



Troubleshooting

- 16 Tips for operators and service technicians** 34



Appendix

- 17 Handover record** 36
- 18 Country representatives** 38

Important information

1 About this document

These installation and operating instructions represent part of the unit.



The manufacturer and the distributor will not offer any guarantee or accept any liability for the safe operation and the safe functioning of the unit if the instructions and information in these installation and operating instructions are not complied with.

The German version of the installation and operating instructions is the original manual. All other languages are translations of the original manual. These installation and operating instructions apply to:

Primo

REF: 5152-01

Duo

REF: 5252100001; 5252-01; 5252-01/Service; 5252-51; 5252100024

Trio

REF: 5352-01; 5352100001; 5352100013

Quattro

REF: 5452-51; 5452100001

Quattro Tandem

REF: 4682-52; 4682-53

1.1 Warnings and symbols

Warnings

The warnings in this document are intended to draw your attention to possible injury to persons or damage to machinery.

The following warning symbols are used:



General warning symbol



Warning – dangerous high voltage



Warning – hot surfaces



Warning - automatic start-up of the unit

The warnings are structured as follows:



SIGNAL WORD

Description of the type and source of danger

Here you will find the possible consequences of ignoring the warning

- Follow these measures to avoid the danger.

The signal word differentiates between four levels of danger:

- **DANGER**
Immediate danger of severe injury or death
- **WARNING**
Possible danger of severe injury or death
- **CAUTION**
Risk of minor injuries
- **NOTICE**
Risk of extensive material/property damage

Other symbols

These symbols are used in the document and on or in the unit:



Note, e.g. specific instructions regarding efficient and cost-effective use of the unit.



Observe the operating instructions.



Disconnect all power from the unit.



Refer to the accompanying electronic documents.



Air



Dispose of correctly in accordance with EU Directive 2012/19/EU (WEEE).



CE labelling with the number of the notified body



Order number



Serial number



Medical device



Health Industry Bar Code (HIBC)



1.2 Copyright information

All circuits, processes, names, software programs and units mentioned in this document are protected by copyright.

The Installation and Operating Instructions must not be copied or reprinted, neither in full nor in part, without written authorisation from the copyright owner.

2 Safety

The unit has been developed and designed in such a way that dangers are effectively ruled out if used in accordance with the Intended Use.

Despite this, the following residual risks can remain:

- Personal injury due to incorrect use/misuse
- Personal injury due to mechanical effects
- Personal injury due to electric shock
- Personal injury due to radiation
- Personal injury due to fire
- Personal injury due to thermal effects on skin
- Personal injury due to lack of hygiene, e.g. infection



WARNING

The development of emphysema

Soft tissue can be damaged as a result of careless handling.

- › Do not dwell in the area being treated for any longer than is necessary.

2.1 Intended purpose

The compressor is designed to supply compressed air for dental applications.

2.2 Intended use

The air supplied by the compressor is suitable for driving dental tools.

The compressed air generated by the compressor is delivered to the pipeline system of the surgery. The entire compressed air system must be designed in such a way that the quality of the compressed air generated by the compressor is not impaired.

With this prerequisite, the air provided by the compressor is also suitable for blow-drying tooth preparations.

2.3 Improper use

Any use of this appliance / these appliances above and beyond that described in the Installation and Operating Instructions is deemed to be incorrect usage. The manufacturer cannot be held liable for any damage resulting from incorrect usage. The operator will be held liable and bears all risks.

**WARNING****Risk of explosion due to ignition of combustible materials**

- › Do not operate the unit in any rooms in which inflammable mixtures may be present, e.g. in operating theatres.

- › The unit is not suitable for providing an air supply to respirators.
- › This unit is not suitable for drawing up fluids or for compressing aggressive gases or potentially explosive gases.

2.4 General safety information

- › Always comply with the specifications of all guidelines, laws, and other rules and regulations applicable at the site of operation for the operation of this unit.
- › Check the function and condition of the unit prior to every use.
- › Do not convert or modify the unit.
- › Comply with the specifications of the Installation and Operating Instructions.
- › The Installation and Operating Instructions must be accessible to all operators of the unit at all times.

2.5 Specialist personnel**Operation**

Unit operators must use their training and knowledge to ensure safe and correct handling.

- › Instruct or have every operator instructed in the handling of the unit.

The following groups are not permitted to operate or use a commercially operated unit:

- People without the necessary experience and knowledge
- People with reduced physical, sensory or mental capabilities
- Children

Installation and repairs

- › Have the manufacturer or a qualified company authorised by the manufacturer perform mounting, new installations, modifications, expansions and repairs.

2.6 Electrical safety

- › Observe and comply with all the relevant electrical safety regulations when working on the unit.
- › Replace any damaged cables or plugs immediately.

2.7 Notification requirement of serious incidents

The operator/patient is required to report any serious incident that occurs in connection with the device to the manufacturer and to the competent authority of the Member State in which the operator and/or patient is established/resident.

2.8 Only use original parts

- › Only use accessories and optional articles named or authorised by the manufacturer.
- › Only use only original wear parts and replacement parts.



The manufacturer and distributor accept no liability for damages or injury resulting from the use of non-approved accessories, optional accessories, or from the use of non-original wear parts or replacement parts.

The use of non-approved accessories, optional accessories or non-genuine wear parts / replacement parts (e.g. mains cables) can have a negative effect in terms of electrical safety and EMC.

2.9 Transport

The original packaging provides optimum protection for the unit during transportation.

If required, the original packaging for the unit can be ordered.



The manufacturer and the distributor do not accept liability, even during the warranty period, for damage during transportation due to improper packaging.

- › Only transport the unit in its original packaging.
- › Keep the packing materials out of the reach of children.

2.10 Disposal



The unit must be disposed of properly. Within the European Union, the unit must be disposed of in accordance with EU Directive 2012/19/EU (WEEE).

- › If you have any questions about the correct disposal of parts, please contact your dental trade supplier.



An overview of the waste keys for Dürr Dental products can be found in the download area:



<http://qr.duerdental.com/P007100155>



Product description

3 Overview

3.1 Scope of delivery

The following items are included in the scope of delivery (possible variations due to country-specific requirements and/or import regulations):

<i>Primo 230 V, 1~, with membrane drying unit</i>	5152-01
<i>Duo 110 V, 1~, with membrane drying unit</i>	5252100001
<i>Duo 230 V, 1~, with membrane drying unit</i>	5252-01
<i>Duo 230 V, 1~, with membrane drying unit</i>	5252-01/Service
<i>Duo 230 V, 1~, with membrane drying unit</i>	5252100024
<i>Duo 400 V, 3~, with membrane drying unit</i>	5252-51
<i>Trio 230 V, 1~, with membrane drying unit</i>	5352-01
<i>Trio 230 V, 1~, with membrane drying unit</i>	5352100001
<i>Trio 230 V, 1~, with membrane drying unit</i>	5352100013
<i>Quattro 400 V, 3~, with membrane drying unit*</i>	5452-51
<i>Quattro 400 V, 3~, with membrane drying unit*</i>	5452100001
<i>Quattro Tandem 230 V, 3~, with membrane drying unit</i>	4682-52
<i>Quattro Tandem 400 V, 3~, with membrane drying unit</i>	4682-53
– Fabric reinforced hose	
– Hose nozzle	
– Hose clamp	
– Short information	
– Appliance log book	
– Collector tray	

3.2 Optional items

The following items can optionally be used with the unit; these items do not bear the CE mark:

Pressure reducer	6040-992-00
Fine filter	1610-121-00
Wooden cabinet for sound insulation of Primo and Duo Compressors	5150-500-00
Wooden cabinet for for sound insulation of Duo Tandem, Trio and Quattro Compressors	4251-500-00

3.3 Wear parts and replacement parts

The following working parts must be replaced at regular intervals (refer also to "Maintenance"); these articles do not bear the CE mark:

Air intake filter	0832-982-00
Fine filter	1610-121-00
Virus bacteria filter	1650100172
Coalescence filter	1650200323



To configure the required filters or filter sets, you can also use our filter configurator at:

www.duerrdental.com/filterkonfigurator



Any repairs exceeding routine maintenance may only be carried out by qualified personnel or our service.



Information about replacement parts is available from the portal for authorised specialist dealers at:

www.duerrdental.net



If the mains cable of this unit is damaged it must only be replaced by an original mains cable from the manufacturer.

4 Technical data

4.1 Primo

Electrical data		5152-01	
Nominal voltage	V	230	
Mains frequency	Hz	50	60
Nominal current at 8 bar (0.8 MPa)	A	4.4	4.3
Motor protection switch, recommended setting	A	5	4.5
Type of protection		IP 24	
Mains fuse*	A	10	

* Circuit breaker fuse characteristics B, C or D in accordance with EN 60898-1

General technical data			
Pressure tank volume	l	20	
Suction power, approx.	l/min	105	125
Delivery at 5 bar (0.5 MPa)*	l/min	61	71
Pressure build-up phase 0-7.5 bar (0-0.75 MPa), approx.	s	155	130
Duty cycle	%	100	
Start-up pressure	bar (MPa)	6 (0.6)	
Cut-off pressure	bar (MPa)	7.8 (0.78)	
Cut-off pressure, max. adjustable	bar (MPa)	9.5 (0.95)	
Safety valve, maximum permissible operating pressure	bar (MPa)	10 (1)	
Pressure dew point at 7 bar (0.7 MPa)**	°C	≤ +5	
Dimensions (H x W x D) ***	cm	69 x 49 x 47	
Weight	kg	45	
Noise level ****			
without sound insulation	dB(A)	65	66
with sound insulation	dB(A)	49	50

* Delivery without membrane drying unit, at +20°C and 1013 mbar (0.1 MPa)

** Value determined at an ambient temperature of +40 °C

*** Values without accessories and add-on parts

**** Noise level in accordance with ISO 3744

Air purity

Air quality in accordance with ISO 22052 chap. 5.3 fulfilled

Classification

Medical Device Class (MDR) IIa

4.2 Duo

Electrical data	5252-01			5252-51	
		5252-01/Service 5252100024			
Rated voltage	V	230		400	
Mains frequency	Hz	50	60	50	60
Nominal current at 8 bar (0.8 MPa)	A	6.3	7.0	3.1	2.5
Motor protection switch, recommended settings	A	6.5	7.6	3.1	2.5
Type of protection		IP 24		IP 24	
Mains fuses *	A	10		10	
Max. permissible mains impedance in accordance with EN 61000-3-11 **	Ω	≤ 0.142		-	

* Circuit breaker fuse characteristics B, C or D in acc. with EN 60898-1

** Mains impedance at 6 switching cycles per hour. If the number of switching cycles per hour is higher a lower mains impedance is required.

General technical data					
Pressure tank volume	l	20		20	
Suction power, approx.	l/min	210	255	210	255
Delivery at 5 bar (0.5 MPa)*	l/min	125	145	125	145
Pressure build-up phase 0 - 7.5 bar (0 - 0.75 MPa) approx.	s	70	60	70	60
Duty cycle	%	100		100	
Cut-In pressure	bar (MPa)	6 (0.6)		6 (0.6)	
Cut-out pressure	bar (MPa)	7.8 (0.78)		7.8 (0.78)	
Cut-off pressure, max. adjustable	bar (MPa)	9.5 (0.95)		9.5 (0.95)	
Safety valve, maximum permissible operating pressure	bar (MPa)	10 (1)		10 (1)	
Pressure dew point at 7 bar (0.7 MPa)**	$^{\circ}\text{C}$	$\leq +5$		$\leq +5$	
Dimensions (H x W x D) ***	cm	69 x 49 x 47		69 x 49 x 47	
Weight	kg	50		50	
Noise level ****					
without sound insulation	dB(A)	66	68	66	68
with sound insulation	dB(A)	51	-	51	50

* Delivery without membrane drying unit, at +20 $^{\circ}\text{C}$ and 1013 mbar (0.1 MPa)

** Value determined at an ambient temperature of +40 $^{\circ}\text{C}$

*** Values without accessories and add-on parts

**** Noise level in accordance with ISO 3744

Air purity

Air quality in accordance with ISO 22052 chap. 5.3 fulfilled

Classification

Medical Device Class (MDR)

IIa

4.3 Duo

Electrical data		5252100001	
Nominal voltage	V	110-115	110-127
Mains frequency	Hz	50	60
Nominal current at 8 bar (0.8 MPa)	A	14.1-14.6	14.2-13.3
Motor protection switch, recommended setting	A	17	16
Type of protection			IP 24
Mains fuse*	A		20

* Circuit breaker fuse characteristics B, C or D in accordance with EN 60898-1

General technical data			
Pressure tank volume	l		20
Suction power, approx.	l/min	210	255
Delivery at 5 bar (0.5 MPa)*	l/min	125	145
Pressure build-up phase 0 - 7.5 bar (0 - 0.75 MPa) approx.	s	70	60
Duty cycle	%		100
Cut-In pressure	bar (MPa)		6 (0.6)
Cut-out pressure	bar (MPa)		7.8 (0.78)
Cut-off pressure, max. adjustable	bar (MPa)		9.5 (0.95)
Safety valve, maximum permissible operating pressure	bar (MPa)		10 (1)
Pressure dew point at 7 bar (0.7 MPa)**	°C		≤ +5
Dimensions (H x W x D) ***	cm		69 x 49 x 47
Weight	kg		50
Noise level ****			
without sound insulation	dB(A)	66	68

* Delivery without membrane drying unit, at +20°C and 1013 mbar (0.1 MPa)

** Value determined at an ambient temperature of +40 °C

*** Values without accessories and add-on parts

**** Noise level in accordance with ISO 3744

Air purity

Air quality in accordance with ISO 22052 chap. 5.3 fulfilled

Classification

Medical Device Class (MDR)

IIa

4.4 Trio

Electrical data	5352-01	
	5352100001 5352100013	
Rated voltage	V	230
Mains frequency	Hz	50
Nominal current at 8 bar (0.8 MPa)	A	8.6
Motor protection switch, recommended settings	A	8.6
Type of protection		IP 24
Mains fuses *	A	10
Max. permissible mains impedance in accordance with EN 61000-3-11	Ω	≤ 0.078

* Circuit breaker fuse characteristics B, C or D in acc. with EN 60898-1

General technical data		
Pressure tank volume	l	50
Suction power, approx.	l	315
Delivery at 5 bar (0.5 MPa)*	l/min	181
Pressure build-up phase 0 - 7.5 bar (0 - 0.75 MPa) c.	s	140
Duty cycle	%	100
Cut-in pressure	bar (MPa)	6 (0.6)
Cut-out pressure	bar (MPa)	7.8 (0.78)
Cut-off pressure, max. adjustable	bar (MPa)	9.5 (0.95)
Safety valve, maximum permissible operating pressure	bar (MPa)	10 (1)
Pressure dew point at 7 bar (0.7 MPa)**	$^{\circ}\text{C}$	$\leq +5$
Dimensions (H x W x D) ***	cm	76 x 74 x 52
Weight	kg	80
Noise level ****		
without sound insulation	dB(A)	67
with sound insulation	dB(A)	49

* Delivery without membrane drying unit, at +20 $^{\circ}\text{C}$ and 1013 mbar (0.1 MPa)

** Value determined at an ambient temperature of +40 $^{\circ}\text{C}$

*** Values without accessories and add-on parts

**** Noise level in accordance with ISO 3744

Air purity

Air quality in accordance with ISO 22052 chap. 5.3 fulfilled

Classification

Medical Device Class (MDR)

IIa

4.5 Quattro

Electrical data		5452-51 5452100001	
Nominal voltage	V	400	
Mains frequency	Hz	50	60
Nominal current at 8 bar (0.8 MPa)	A	4.4	4.8
Motor protection switch, recommended setting	A	5.0	5.0
Type of protection		IP 24	
Mains fuse*	A	10	
Max. permissible mains impedance in accordance with EN 61000-3-11**	Ω	≤ 0.24	

* Circuit breaker fuse characteristics B, C or D in accordance with EN 60898-1

** Mains impedance at 6 switching cycles per hour. If the number of switching cycles per hour is higher, a lower mains impedance is required.

General technical data			
Pressure tank volume	l	50	
Suction power, approx.	l/min	420	505
Delivery at 5 bar (0.5 MPa)*	l/min	258	293
Pressure build-up phase 0 - 7.5 bar (0 - 0.75 MPa) c.	s	95	80
Duty cycle	%	100	
Cut-In pressure	bar (MPa)	6 (0.6)	
Cut-out pressure	bar (MPa)	7.8 (0.78)	
Cut-off pressure, max. adjustable	bar (MPa)	9.5 (0.95)	
Safety valve, maximum permissible operating pressure	bar (MPa)	10 (1)	
Pressure dew point at 7 bar (0.7 MPa)**	$^{\circ}\text{C}$	$\leq +5$	
Dimensions (H x W x D) ***	cm	76 x 74 x 52	
Weight	kg	85	
Noise level ****			
without sound insulation	dB(A)	69	70
with sound insulation	dB(A)	53	54

* Delivery without membrane drying unit, at +20 $^{\circ}\text{C}$ and 1013 mbar (0.1 MPa)

** Value determined at an ambient temperature of +40 $^{\circ}\text{C}$

*** Values without accessories and add-on parts

**** Noise level in accordance with ISO 3744

Air purity

Air quality in accordance with ISO 22052 chap. 5.3 fulfilled

Classification

Medical Device Class (MDR)

IIa

4.6 Quattro Tandem

Electrical data		4682-52		4682-53	
Nominal voltage	V	230 / 3~		400 / 3~	
Mains frequency	Hz	50	60	50	60
Nominal current at 8 bar (0.8 MPa)	A	15.2	16.6	8.8	9.6
Motor protection switch, recommended setting	A	9	9	5	5
Type of protection		IP 24		IP 24	
Mains fuse*	A	20		20	
Max. permissible mains impedance in accordance with EN 61000-3-11**	Ω	≤ 0.445		≤ 0.18	

* Circuit breaker fuse characteristics B, C or D in accordance with EN 60898-1

** Mains impedance at 6 switching cycles per hour. If the number of switching cycles per hour is higher, a lower mains impedance is required.

General technical data					
Pressure tank volume	l	90		90	
Suction power, approx.	l/min	845	1010	845	1010
Delivery at 5 bar (0.5 MPa)*	l/min	516	586	516	586
Pressure build-up phase 0 - 7.5 bar (0 - 0.75 MPa) c.	s	90	80	90	80
Duty cycle	%	100		100	
Start-up pressure	bar (MPa)	6.5 (0.65)		6.5 (0.65)	
Cut-off pressure	bar (MPa)	8.5 (0.85)		8.5 (0.85)	
Cut-off pressure, max. adjustable	bar (MPa)	9.5 (0.95)		9.5 (0.95)	
Safety valve, maximum permissible operating pressure	bar (MPa)	10 (1)		10 (1)	
Pressure dew point at 7 bar (0.7 MPa)**	°C	≤ +5		≤ +5	
Dimensions (H x W x D) ***	cm	76 x 102 x 62		76 x 102 x 62	
Weight	kg	170		170	
Noise level ****	dB(A)	72	73	72	73

* Delivery without membrane drying unit, at +20°C and 1013 mbar (0.1 MPa)

** Value determined at an ambient temperature of +40 °C

*** Values without accessories and add-on parts

**** Noise level in accordance with ISO 3744

Air purity

Air quality in accordance with ISO 22052 chap. 5.3 fulfilled

Classification

Medical Device Class (MDR)

Ila

4.7 Filter

Filter mesh size		
Air intake filter	μm	3
Fine filter	μm	3
Virus bacteria filter	μm	0.01
Coalescence filter	μm	0.01

4.8 Ambient conditions

Ambient conditions during storage and transport		
Temperature	°C	-10 - +55
Relative humidity	%	< 95

Ambient conditions during operation		
Temperature	°C	+10 - +40
Ideal temperature	°C	+10 - +25
Relative humidity	%	< 95

4.9 Distance between rubber feet

Distances between the rubber feet for different pressure vessel volumes:

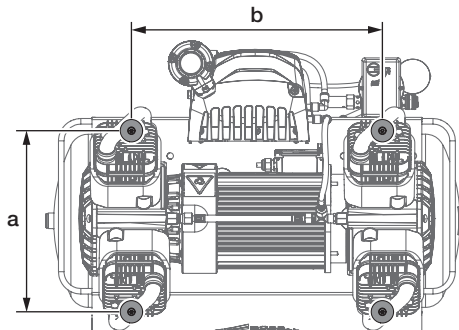

	a (cm)	b (cm)
20 l	23	27
50 l	32.5	45
90 l	32.5	59

4.10 Type plate

Complete system

The type plate of the overall system is located on the mounting plate for the compressor unit.

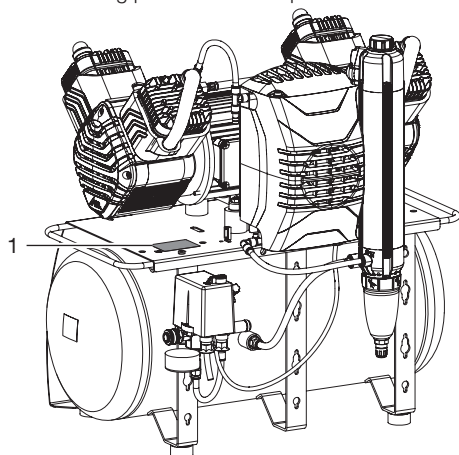

1 Type plate for the complete system

Compressor unit

The type plate of the compressor unit is located on the crankcase below the cylinder.

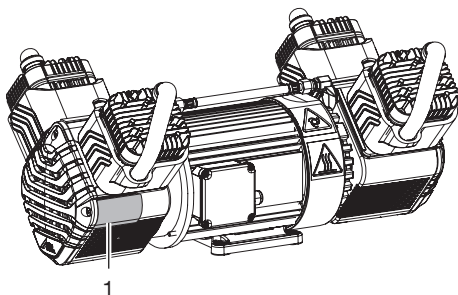

1 Compressor unit type plate

Membrane drying unit

The type plate of the membrane drying unit is located on the side of the membrane drying unit.

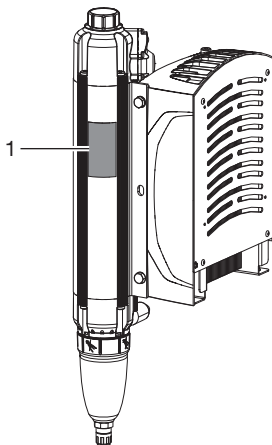

1 Membrane drying unit type plate

4.11 Evaluation of conformity

This device has been subjected to conformity acceptance testing in accordance with the current relevant European Union guidelines. This equipment conforms to all relevant requirements.

5 Operation

5.1 Duo with membrane drying unit

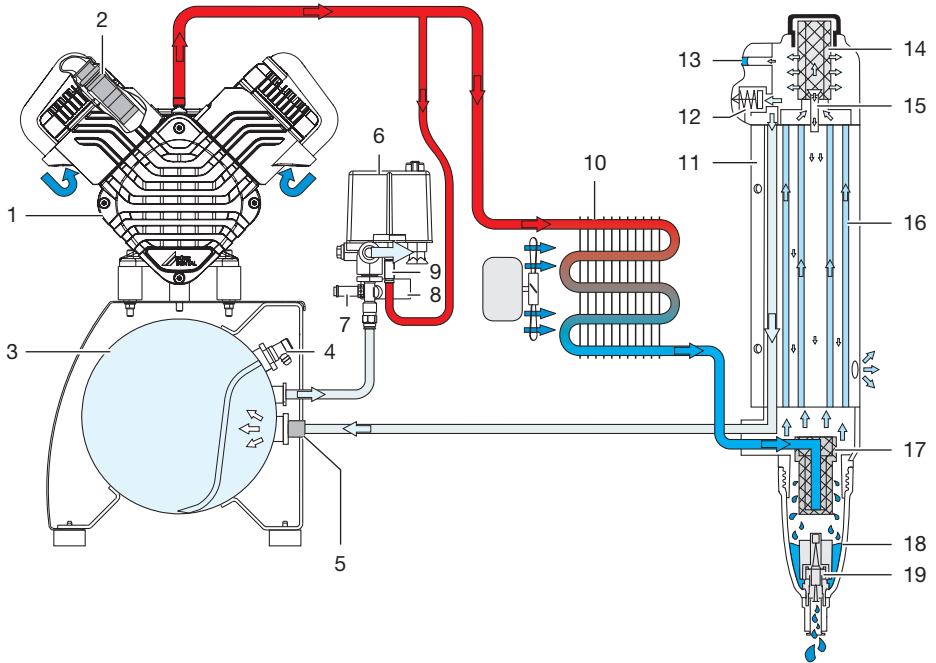

- 1 Compressor unit
- 2 Air intake filter
- 3 Pressure vessel
- 4 Condensate drain valve
- 5 Non-return valve
- 6 Pressure switch
- 7 Safety valve
- 8 Pressure gauge/display
- 9 Pressure relief valve
- 10 Cooler with ventilating fan
- 11 Membrane drying unit
- 12 Pressure limiting valve
- 13 Humidity display
- 14 Fine or virus bacteria filter
- 15 Rinsing nozzle
- 16 Membrane fibre
- 17 Coalescence filter
- 18 Water collection chamber
- 19 Water outlet valve

The compressor unit draws in atmospheric air and compresses it without oil. It then transports the oil-free compressed air to the membrane drying unit. The cooler and the membrane dryer extract moisture from the compressed air. The oil-free, hygienic and dry air is stored in the pressure tank ready for use in connected devices.

Assembly

6 Requirements

i The unit must not be set up or operated within the vicinity of the patients (within a radius of 1.5 m).

The unit can be installed either at the same level as the surgery room or on a floor below (e.g. cellar).

Due to the amount of noise generated, we recommend that the unit is installed in an adjoining room.

The pipes provided on-site must at least meet the country-specific requirements for drinking water.

The compressed air network to which the unit is connected must be designed for the maximum pressure of the unit (10 bar).

i Further information can be found in our separate planning information leaflet for compressed air.

6.1 Installation/setup room

The room chosen for set up must fulfil the following requirements:

- Closed, dry, well-ventilated room
- Should not be a room made for another purpose (e. g. boiler room or wet cell)
- If the unit is installed in a machine room, e.g. in an adjoining room or cellar, the requirements set out in DIN EN ISO 22052 must be observed.



NOTICE

Risk of overheating due to insufficient ventilation

The units generates heat. Possibility of heat damage and/or reduced service life of the unit.

- › Do not cover the unit.
- › Install a fan for auxiliary ventilation in rooms where ambient temperatures exceed ≥ 40 °C while the unit is in operation.

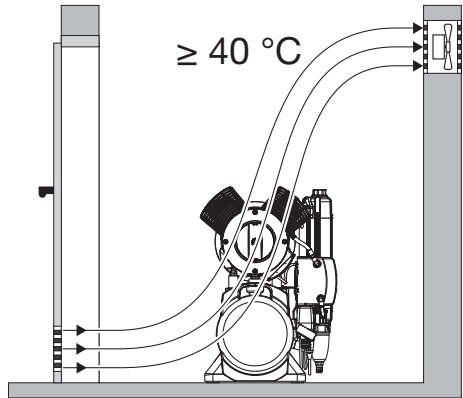

6.2 Setup

The following conditions must be taken into account for installation:

i The air is filtered when it is sucked in. This does not alter the composition of the air. For this reason it is important to keep the sucked-in air free of harmful substances (e.g. do not suck in exhaust gases or contaminated exhaust air).

- Clean, level and sufficiently stable subsurface (note the weight of the unit).
- Type plate easy to read.
- Unit easy to access for operation and maintenance.
- Easy-to-access power outlet to which the unit is connected.
- Maintain sufficient distance to the wall (at least 20 cm).
- The compressed air pipe should be routed as closely as possible to the place of installation (note the length of the hose supplied).

6.3 Information about electrical connections

- › Ensure that the electrical connections to the mains power supply are established in accordance with current valid national and local regulations and standards governing the installation of low voltage units in medical facilities.
- › Observe the current consumption of the devices that are to be connected.

7 Transport



WARNING

Risk of explosion of the pressure tank and pressure hoses

- › The pressure tank and the pressure hoses must be vented before they are stored or transported.
- › Protect the unit against moisture, dirt and extreme temperatures during transport ("4 Technical data").
- › Always make sure that the condensate collector chamber is empty before transporting the unit ("15 Taking out of use").
- › Always transport the unit in an upright position.
- › Only transport the unit using the transport handles provided.
- › Check the unit for transport damage.

8 Quattro Tandem assembly and installation

For weight reasons the unit is not supplied fully assembled. Instead, the compressor units are installed at the site of use.

- › Set up the tank at the planned installation site.
- › Screw the vibration reducers into the motor mounting.
- › Place the compressor units on the vibration reducers.
- › Attach the compressor units with the lock washers and nuts.

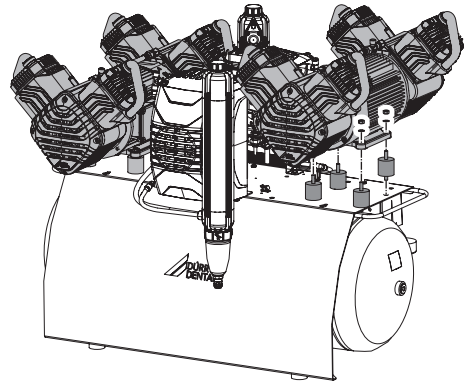

- › Insert the compressed air connections from the compressor unit into the cooler.
- › Plug in the electrical connections of the compressor units at the control box. Connect the left-hand unit to the left-hand plug connector and the right-hand unit to the right-hand plug connector.

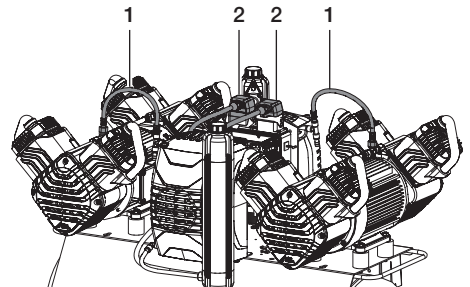

- 1 Compressed air connections
- 2 Electrical connections

9 Installation

9.1 Remove the transport locks

For safe transport, the unit is secured with foam padding blocks and a transport strap.

- › Cut and remove the transport strap.
- › Remove the foam padding blocks.

9.2 Establishing the compressed air connection



The supplied flexible pressure hose between the pipe system and the compressor prevents vibrations from being transmitted and thus reduces noise. This ensures safe and reliable operation.

- › Connect the pre-assembled connecting sleeve of the pressure hose to the quick release coupling.
- › Measure the required length of the pressure hose and shorten if necessary.
- › Press a fitting hose connector (not included in the scope of delivery) onto the pressure hose (internal diameter 10 mm) and secure it with a hose clip.
- › Connect the connecting sleeve of the pressure hose to the compressed air tube.

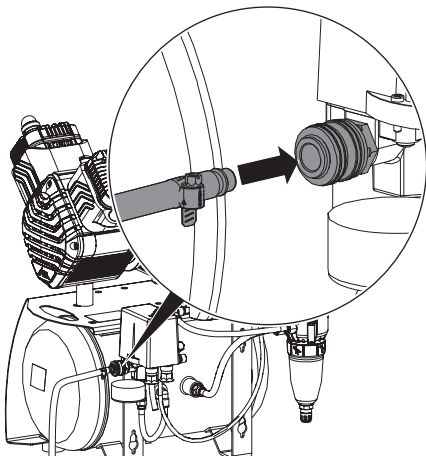

9.3 Pressure reducer

- › Insert the pressure reducer into the quick release coupling.
- › Insert the pressure hose into the quick release coupling on the pressure reducer.

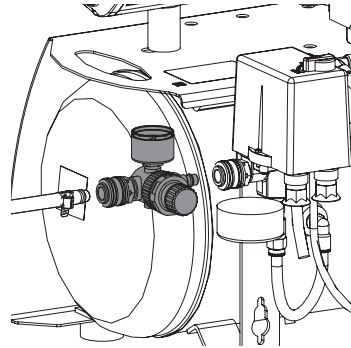

9.4 Place a collector tray underneath

During operation, condensation water on the unit is continuously separated and automatically drained. In order to prevent water damage due to drained condensation, it is collected in the collector tray.



As an option, the condensation can also be drained through a hose into the waste water system. Always comply with applicable national regulations for waste water systems.

- › Place a collector tray under the condensate separator or the membrane drying unit (depending on type).

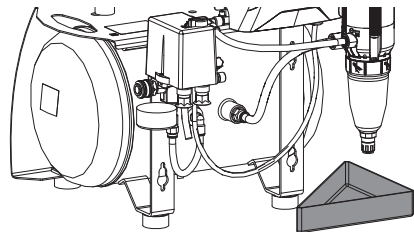

9.5 Electrical connections

Safety when making electrical connections



The unit has no main power switch. For this reason it is important that the unit is set up in such a way that the plug can be easily accessed and unplugged if required.

- › The unit must only be connected to a correctly installed power outlet.

- › Make sure that none of the electrical cables leading to the unit are under any mechanical tension.
- › Before initial start-up check that the mains supply voltage and the voltage stated on the type plate match (see also "4. Technical data").

Establishing the electrical connections



DANGER

Risk of electric shock due to defective mains cable

- › Mains cables must not be allowed to come into contact with any hot surfaces on the unit.
- › Connect the mains plug to an earthed power outlet.

10 Commissioning



In many countries technical medical products and electrical devices are subject to regular checks at set intervals. The owner must be instructed accordingly.

- › Turn on the unit power switch or the main surgery switch.
- › Carry out an electrical safety check in accordance with applicable local regulations (e.g. the German Ordinance on the Installation, Operation and Use of Medical Devices / Medizinprodukte-Betreiberverordnung) and record the results as appropriate, e.g. in the technical log book.
- › Carry out and document the instruction and handover for the unit.



A sample handover report is included in the attachment.

10.1 Check the motor protection switch

After installation of the compressor the motor protection switch needs to be checked and adjusted if it is not set up correctly. It was set to the recommended setting in the factory (see "4 Technical data").

- › Switch on the unit at the pressure switch by rotating the switch to the "I" position.

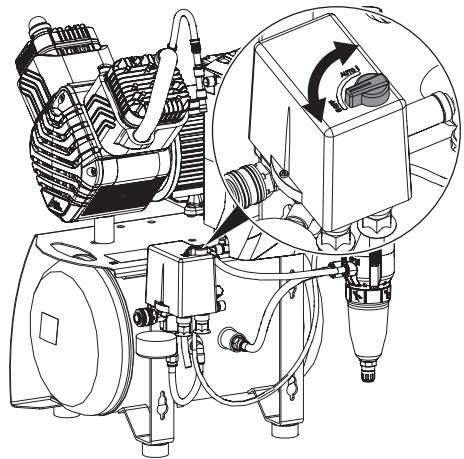

- › Measure the maximum current consumption (this is the value just before the cut-off pressure is reached).
If the reading deviates from the recommended setting then the motor protection switch needs to be adjusted (see "11.2 Adjusting the motor protection switch").

10.2 Checking the switch-on/cut-off pressure

The switch-on/cut-off pressure is preset at the factory. Check the setting during first start-up.

- › Switch on the unit at the pressure switch by rotating it to the position "I AUTO".
- › Read off the cut-off pressure from the pressure gauge.
- › Drain the air from the pressure tank (e.g. via the condensate drain valve) until the unit starts and then close it again.
- › Read off the pressure when the unit switches on.

If the readings deviate from the values preset at the factory, adjust the pressure switch to the factory settings.

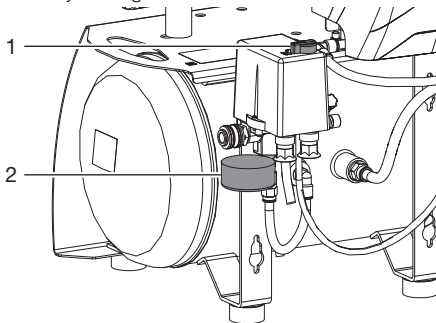

- 1 On/off switch
- 2 Pressure gauge

10.3 Draining the condensation water

Temperature changes during transport may cause condensation water to accumulate in the pressure tank. The condensation water can only be drained from the pressurised pressure tank.

- › Switch on the unit at the pressure switch and wait until the cut-off pressure is reached.
- › At maximum tank pressure, slowly open the condensate drain valve.

- › Close the condensate drain valve as soon as all of the accumulated condensation water has been blown out.

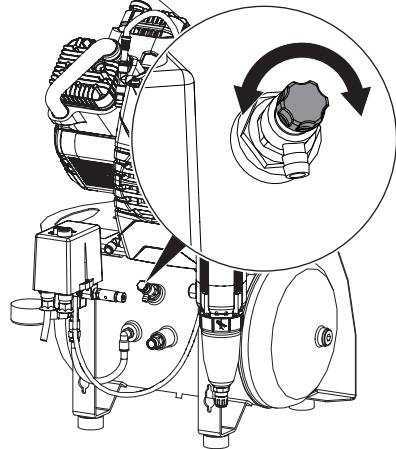

10.4 Adjusting the rate of flow at the pressure reducer

The pressure reducer regulates the rate of flow in the system and adjusts it to the required operating pressure. In order to adjust the rate of flow air needs to be extracted via a consumer.

- › Activate the air consumer unit.
- › Lift the rotary knob at the pressure reducer.
- › Adjust the rate of flow via the rotary knob.
Turn the knob in the "+" direction to increase the rate of flow.
Turn the knob in the "-" direction to reduce the rate of flow.
- › Press in the rotary knob until it engages and cannot be adjusted.

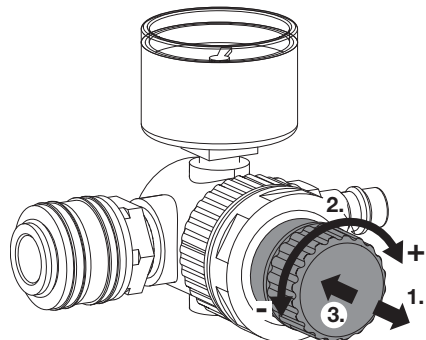

11 Adjustment options

11.1 Adjusting the pressure switch



WARNING

Risk of explosion of the pressure vessel

The pressure vessels used in the compressors are designed to withstand continuous pressure changes of 2 bar and can be used continuously under these pressure changes.

- › For load changes > 2 bar (max. permissible: 3 bar), comply with the maximum load change cycles specified in the operating instructions of the pressure vessel.



DANGER

Exposed live parts

- Risk of electric shock due to live parts
- › Disconnect all power from the device.
- › Use insulated tools.
- › Do not touch live parts.



The cut-off pressure must be at least 0.5 bar (0.05 hPa) below the maximum pressure of 10 bar (1 hPa) of the safety valve. Otherwise the safety valve can open too early, which will prevent the compressor unit from attaining the cut-off pressure, as a result of which it will run continuously. The maximum permitted pressure is marked by a red line on the attached pressure gauge.

If the read-off values differ from the factory settings or if other settings are required, the cut-off pressure of the compressor can be adjusted at the adjusting screw on the pressure switch. The start-up pressure can then be adjusted using the pressure difference Δp .

- › Take off the pressure switch cover.
- › Adjust the cut-off pressure P at the adjustment screw.

The cut-off pressure increases in the "+" arrow direction and decreases in the "-" arrow direction. The pressure difference Δp is also influenced by this adjustment.

- › Adjust the start-up pressure via the pressure difference Δp at the adjustment screw. The pressure difference increases in the "+" arrow direction and decreases in the "-" arrow direction. The maximum permissible pressure difference must not be set to more than 3 bar.

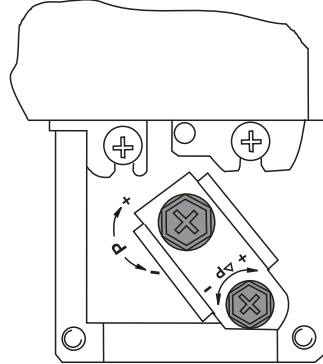

11.2 Adjusting the motor protection switch

Pressure switch

- › Take off the pressure switch cover.
- › Adjust the motor protection switch with the adjustment screw to the measured value (observe the range between the MIN permissible setting and the MAX permissible setting of the motor protection switch, see "4 Technical data").

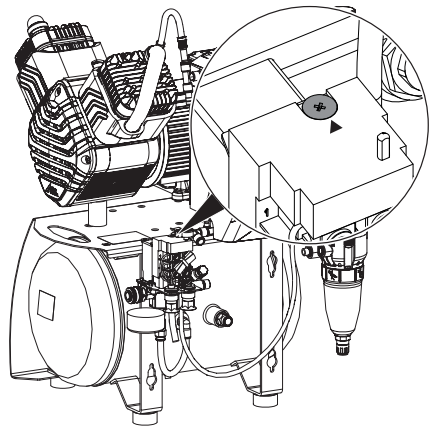

Controller

- › Remove the cover from the controller.
- › Adjust the motor protection switch with the adjustment screw to the measured value (observe the range between the MIN permissible setting and the MAX permissible setting of the motor protection switch, see "4 Technical data").

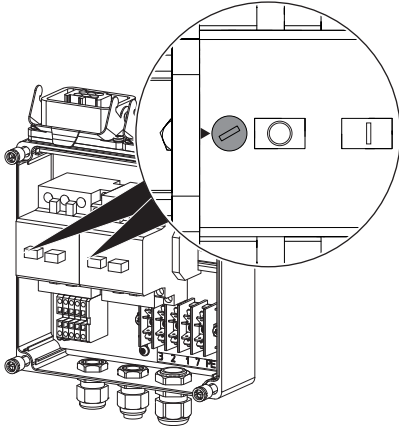

12 Circuit diagrams

12.1 1/N/PE AC 110-127 V, 230 V layout

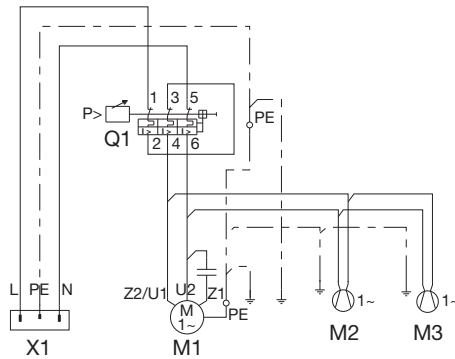

- X1 Mains connection L/N/PE AC 230 V
- Q1 Pressure switch
- M1 Compressor unit
- M2 Fan motor, membrane drying unit
- M3 Fan motor, noise insulation (if required)

12.2 3/N/PE AC 400 V layout

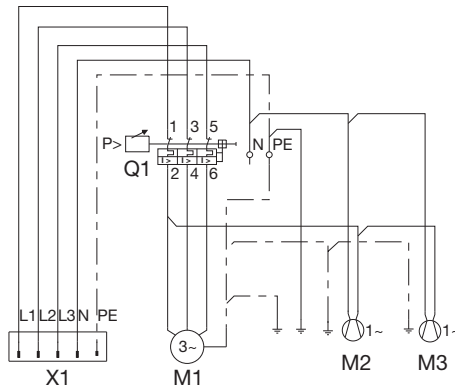

- X1 Mains connection 3/N/PE AC 400 V
- Q1 Pressure switch
- M1 Compressor unit
- M2 Fan motor, membrane drying unit
- M3 Fan motor, noise insulation (if required)

12.3 3/N/PE AC 230 V layout, Quattro Tandem

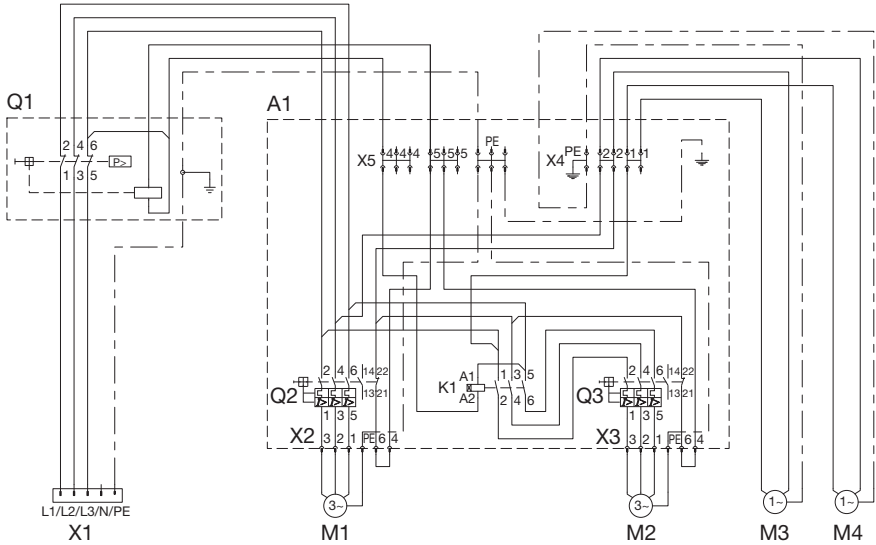

- X1 Mains connection 3/N/PE AC 230 V
- Q1 Pressure switch
- A1 Control box
- X2 Plug connection of compressor unit
- X3 Plug connection of compressor unit
- X4 Distributor rail
- X5 Distributor rail
- Q2 Motor protection switch
- Q3 Motor protection switch
- K1 Time-lag relay
- M1 Compressor unit
- M2 Compressor unit
- M3 Fan motor, membrane drying unit
- M4 Fan motor, membrane drying unit

 Usage

13 Operation



Prior to working on the unit or in case of danger, disconnect it from the mains.

13.1 Switching the unit on/off

- › Switch on the unit at the pressure switch by rotating it to the position "I AUTO".
The compressor unit will start up automatically and fill the pressure tank. When the cut-off pressure is reached the compressor unit switches itself off automatically.
- › The unit can be switched off when required by turning the pressure switch to the "0 OFF" setting.

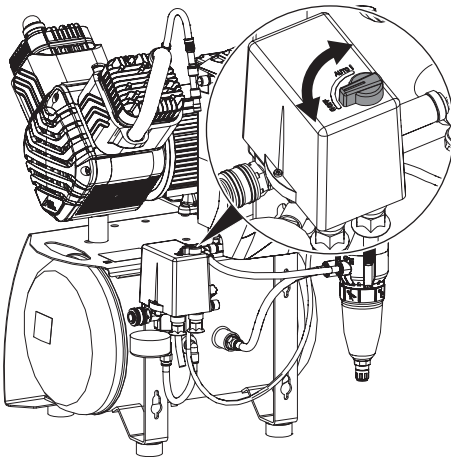

14 Maintenance



Prior to working on the unit or in case of danger, disconnect it from the mains.



WARNING

Risk of infection due to burst filters

Particles enter the compressed air network and can therefore enter the mouth of the patient.

- › Replace filters in accordance with the maintenance schedule.

14.1 Maintenance schedule



NOTICE

Risk of damage to the unit due to blocked filters

Continuous running due to reduced delivery. Damage to the unit due to burst filters.

- › Replace filters in accordance with the maintenance schedule.

Maintenance interval	Maintenance work
Maintenance interval	› Empty the collector tray under the drying unit (the interval may vary depending on the ambient conditions and method of working; empty it daily if the humidity is high).
Annually	<ul style="list-style-type: none"> › Replace the air intake filter in the compressor unit – do this every six months if there is a high concentration of dust. › Replace the fine or virus bacteria filter. › Replace the coalescence filter.
In accordance with national law	<ul style="list-style-type: none"> › Check the safety valve. › Carry out recurring safety inspections (e.g. pressure tank inspections, electrical safety inspections) in accordance with applicable national laws.

14.2 Wear parts and replacement parts

The following wear parts must be replaced at regular intervals:

Air intake filter	0832-982-00
Fine filter	1610-121-00
Virus bacteria filter	1650100172
Coalescence filter	1650200323



To configure the required filters or filter sets, you can also use our filter configurator at:

www.duerredental.com/filterkonfigurator



Any repairs exceeding routine maintenance may only be carried out by qualified personnel or our service.



Information about replacement parts is available from the portal for authorised specialist dealers at:

www.duerredental.net

14.3 Changing the filter



Prior to working on the unit or in case of danger, disconnect it from the mains.



NOTICE

Shortened service life, bad air quality, reduced delivery

- › Replace filters in accordance with the maintenance schedule.

Air intake filter

- › Pull off the noise reducer from the filter.
- › Remove the filter.
- › Insert a new filter.
- › Push on the noise reducer onto the filter.

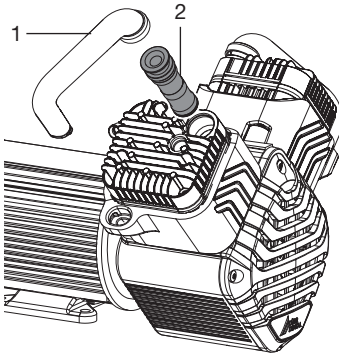

- 1 Noise reducer
- 2 Filters

Fine or virus bacteria filter

- › Unscrew and remove the filter cover.
- › Remove the filter.
- › Insert a new filter.
- › Replace the filter cover and close.

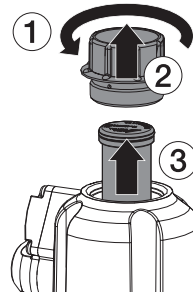

Coalescence filter

- › Unscrew and remove the filter housing.
- › Remove the filter.
- › Insert a new filter.
- › Replace the filter housing and close.

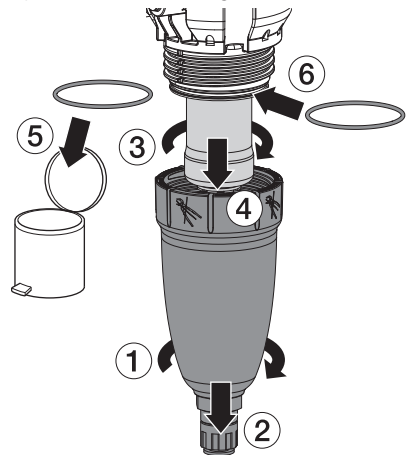

14.4 Checking the safety valve

The functioning of the safety valve must be checked at regular intervals in accordance with national regulations.



WARNING

Risk of damage to the safety valve

Risk of explosion of the pressure tank and pressure hoses due to a defective safety valve

- › Do not use the safety valve to vent the pressure tank.
- › Switch on the unit at the pressure switch and fill the pressure tank to the cut-off pressure.
- › To open, rotate the screw of the safety valve anti-clockwise until the valve begins to blow off. Only allow the safety valve to blow for a short period.
- › Then turn the screw clockwise as far as it will go to close the valve. The valve must now be closed again.

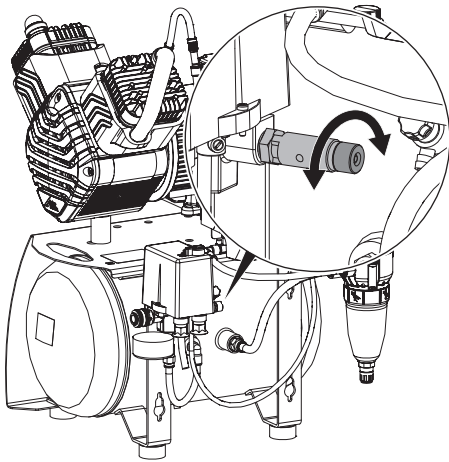

15 Taking out of use

15.1 Taking the unit out of use

If the unit is not to be used for a prolonged period of time, we recommend that it is properly shut down and taken out of use.

To do this, the accumulated condensation water from the unit must be drained.

- › Switch on the unit and wait until the cut-off pressure is reached.

Membrane drying unit

- › While the compressor unit is running, open the condensate drain valve on the membrane drying unit. When no more condensation water emerges, close the condensate drain valve.
- › Switch off the device.

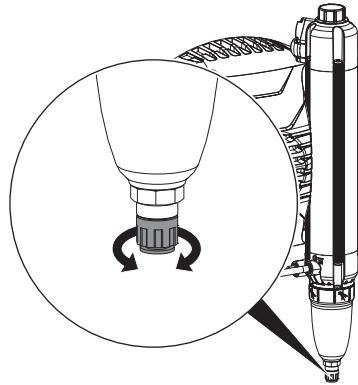

Pressure tank

- › Open the condensate drain valve. Once the start-up pressure has been reached the compressor will switch on.
- › With the compressor switched on and the condensate drain valve open, wait until no more condensation water emerges.
- › Switch off the unit.
- › Close the condensate drain valve when no more air escapes.
- › Disconnect all power from the device.
- › Disconnect the compressed air connection on the quick release coupling.

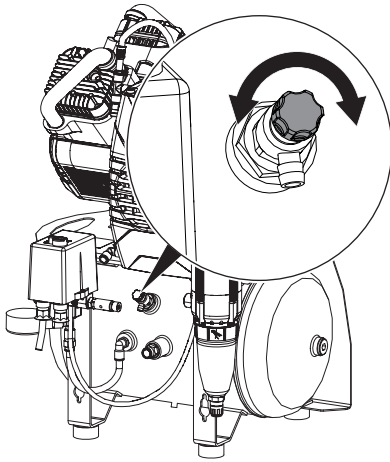

15.2 Storage of the unit



WARNING

Risk of explosion of the pressure tank and pressure hoses

- › The pressure tank and the pressure hoses must be vented before they are stored or transported.
- › Protect the unit against moisture, dirt and extreme temperatures during transport (refer to the section on "Ambient conditions").
- › Only store the unit when it has been completely emptied.

? Troubleshooting

16 Tips for operators and service technicians

 Any repairs exceeding routine maintenance may only be carried out by qualified personnel or our service.

 Prior to working on the unit or in case of danger, disconnect it from the mains.

Error	Possible cause	Remedy
Compressor will not start	No mains voltage. On three-phase units: one phase is missing or not connected (generation of a humming sound)	› Check the mains fuse; if necessary, switch the circuit breaker back on. If the fuse is defective, replace it. Check the mains voltage.
	Undervoltage or overvoltage	› Measure the supply voltage; call an electrician if necessary.
	Pressure relief valve defective, unit starts up against pressure	› Check that the pressure relief valve discharges after the unit is switched off. Make the pressure relief valve operable or replace it.
	Mechanical sluggishness of a unit (piston is stuck); motor protection has tripped	› Switch the unit off and disconnect it from the power supply, remove the fan hood of the blocked compressor and rotate the fan wheel. If this is not possible, replace the piston and cylinder or the complete unit.
Humming noise from motor	Motor capacitor is defective	› Replace the capacitor.
Compressor does not switch off	Wrong size of compressor, air intake too high	› Calculate the air requirement (this can be up to 50 l/min per treatment unit), if necessary install a larger compressor.
	Leak in the compressed air system	› Locate and seal the leak. › Inform a service technician.
	Defective membrane drying unit	› Check whether there is an increased flow of air at the filter housing of the membrane drying unit (bottom), if necessary replace the membrane drying unit.
Compressor switches on from time to time even though no air is being taken for a consumer unit	Leak in the compressed air system	› Locate and seal the leak. › Inform a service technician.

Error	Possible cause	Remedy
Knocking or loud noises on the compressor	Compressor unit defective	› Disconnect all power from the device and inform a service technician.
Reduced delivery. Compressor needs longer to charge the pressure tank, see charging times in "4 Technical data"	Air intake filter dirty	› Replace the air intake filter at least 1x per year. The air intake filter must never be cleaned.
	Defective membrane drying unit	› Replace the membrane drying unit. › Inform a Service Technician.
Water dripping from air consumers	Defective membrane drying unit	› Inform a Service Technician.

Appendix

17 Handover record

This document confirms that a qualified handover of the medical device has taken place and that appropriate instructions have been provided for it. This must be carried out by a qualified adviser for the medical device, who will instruct you in the proper handling and operation of the medical device.

Product name	Order number (REF)	Serial number (SN)

- Visual inspection of the packaging for any damage
- Unpacking the medical device and checking for damage
- Confirmation of the completeness of the delivery
- Instruction in the proper handling and operation of the medical device based on the operating instructions

Notes:

Name of person receiving instruction: **Signature:**



Name and address of the qualified adviser for the medical device:

Date of handover:

Signature of the qualified adviser for the medical device:

--	--

18 Country representatives

Country	Address
GB	 <p>UK Responsible Person: Duerr Dental (Products) UK Ltd. 14 Linnell Way Telford Way Industrial Estate Kettering, Northants NN 16 8PS</p>
UA	 <p>Уповноважений представник в Україні: Приватне підприємство “Галіт” вул. 15 квітня, 6Є, с. Байківці, Тернопільський р-н, 47711, Україна тел.: 0800 502 998; +38 050 338 10 64 www.galit.te.ua; e-mail: office@galit.te.ua</p> <p>Виробник: Дюрр Дентал ЕсЕ Хьопфігхаймер Штрассе 17, Д-74321 Бітігхайм-Біссінген, Німеччина email: info@duerrdental.com</p>
CN	<p>备案人/生产企业：DÜRR DENTAL SE 德国迪珥齿科股份公司 住所/生产地址：Höpfigheimer Str. 17, 74321 Bietigheim-Bissingen, Germany 联系方式： 电话：+ 49 7142 705-0 邮箱：info@duerrdental.com 网址：www.duerrdental.com</p> <p>代理人/售后服务单位：迪珥医疗器械（上海）有限公司 住所：上海市长宁区天山路 641 号 2 号楼 (20 幢) 303 室 联系方式： 电话：+ 86 21 6381 0270 传真：+ 86 21 6381 0290 邮箱：info@duerr.cn 网址：http://www.duerrdental.com</p>



Hersteller / Manufacturer:

DÜRR DENTAL SE
Höfigheimer Str. 17
74321 Bietigheim-Bissingen
Germany
Fon: +49 7142 705-0
www.duerrdental.com
info@duerrdental.com

